

SPECIFICATIONS LEAD SHEET

STYLE NUMBER:	5106	SIZE RANGE:	S-XL
PROTO NUMBER:	1	SAMPLE SIZE:	M
MAIN LABEL:		SEASON:	SS 2023
CONTENT:	70% Cotton, 30% Nylon	CATEGORY:	menswear, outerwear
CARE:	Wash in cold, hang dry	DESCRIPTION:	Utility vest

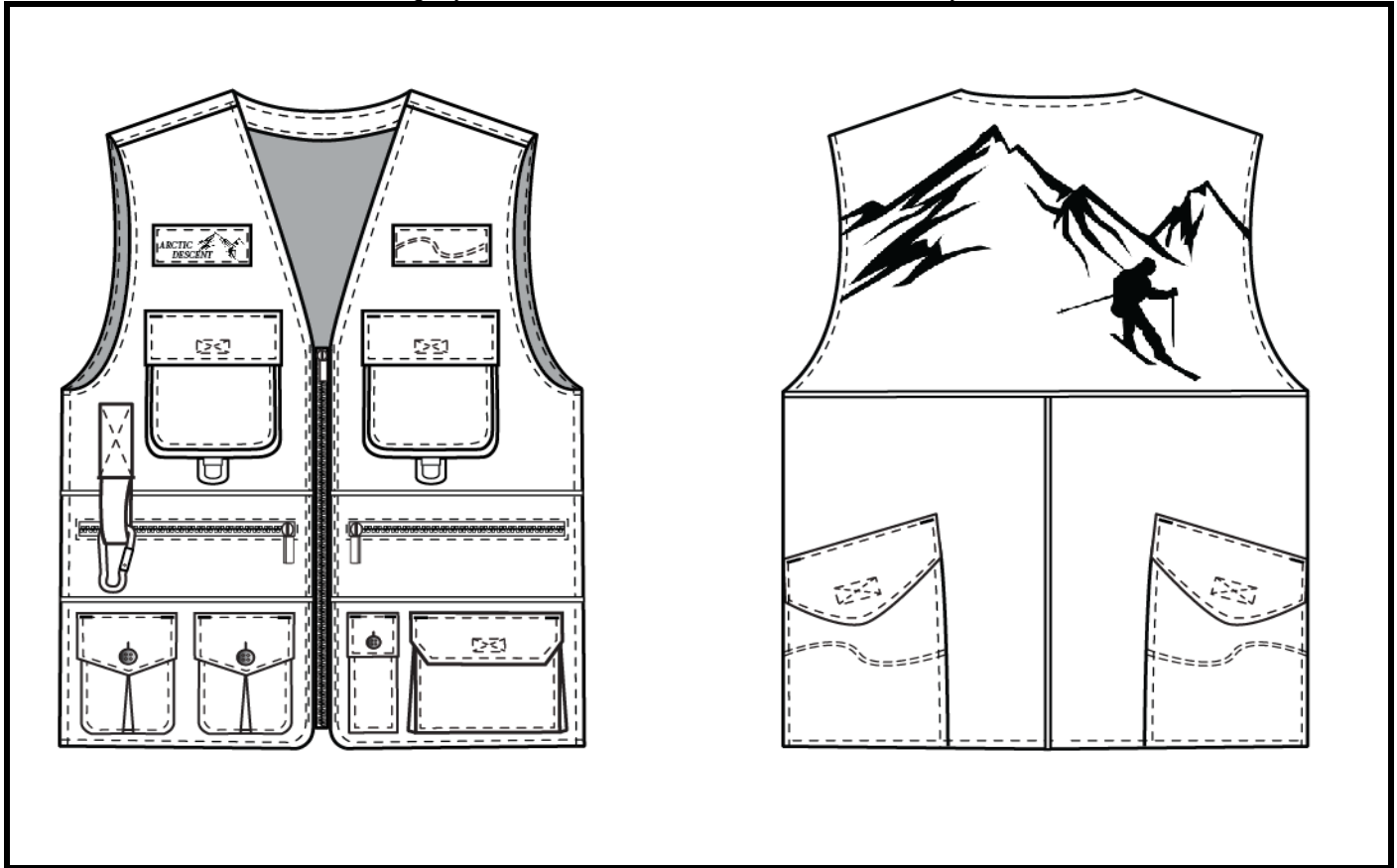

SELF FABRIC:	70% Cotton, 30% Nylon	SUPPLIER:	MOOD Fabrics
CONTRAST 1:		SUPPLIER:	
CONTRAST 2:		SUPPLIER:	
CONTRAST 3:		SUPPLIER:	
CONTRAST 4:		SUPPLIER:	
LINING 1:		SUPPLIER:	
LINING 2:		SUPPLIER:	
POCKETING:	70% Cotton, 30% Nylon	SUPPLIER:	MOOD Fabrics
INTERFACING 1:		SUPPLIER:	
INTERFACING 2:		SUPPLIER:	
INTERFACING 3:		SUPPLIER:	
TRIM 1:	4-Hole, Plastic button	SUPPLIER:	Wawak Sewing
TRIM 2:	Antique brass D-Ring	SUPPLIER:	Wawak Sewing
TRIM 3:	Matte metal carabiner	SUPPLIER:	Wawak Sewing
TRIM 4:	Antique brass zipper	SUPPLIER:	YKK Tokyo
TRIM 5:	Reflective piping	SUPPLIER:	Seattle Fabrics
TRIM 6:	Velcro	SUPPLIER:	Wawak Sewing
TRIM 7:	Wave motif sew on patch	SUPPLIER:	Shopify
TRIM 8:	Arctic Descent sew on patch	SUPPLIER:	Shopify
TRIM 9:	Arctic Descent hangtag	SUPPLIER:	Shopify
TRIM 10:	Wash and care label	SUPPLIER:	Shopify

LABEL PLACEMENT SHEET

STYLE NUMBER: 5106

SIZE RANGE: S-XL

PROTO NUMBER: 1

SAMPLE SIZE: M

DESCRIPTION: Utility vest

SEASON: SS 2023

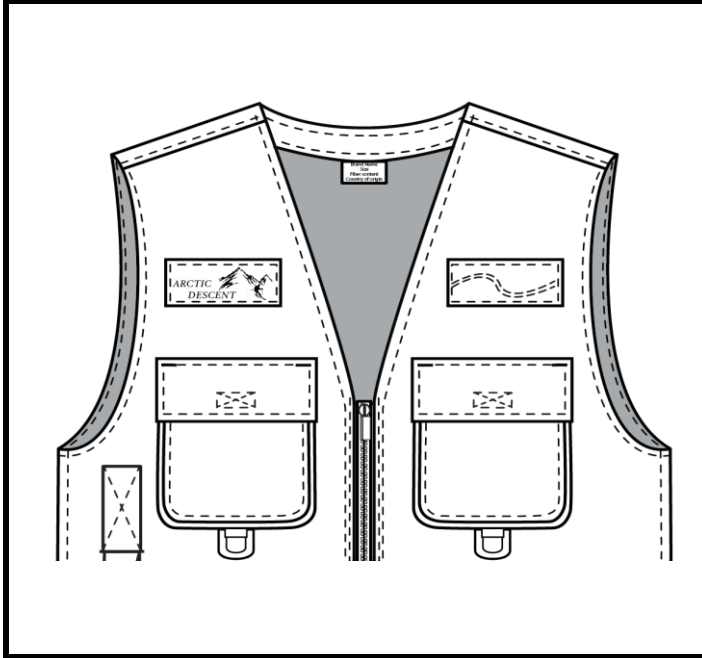

LABEL: Brand name, size, fiber content, country of origin
Below collar on CB

LABEL: Care label
Left sideseam 4" above hem

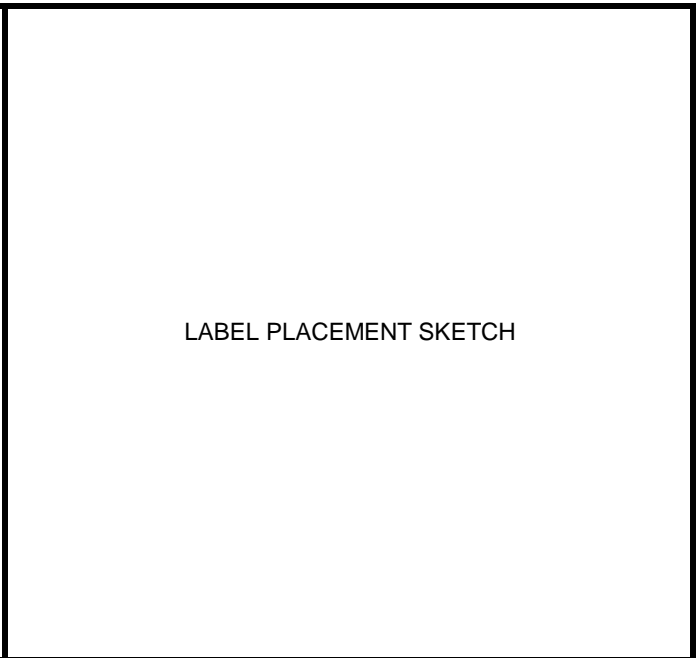
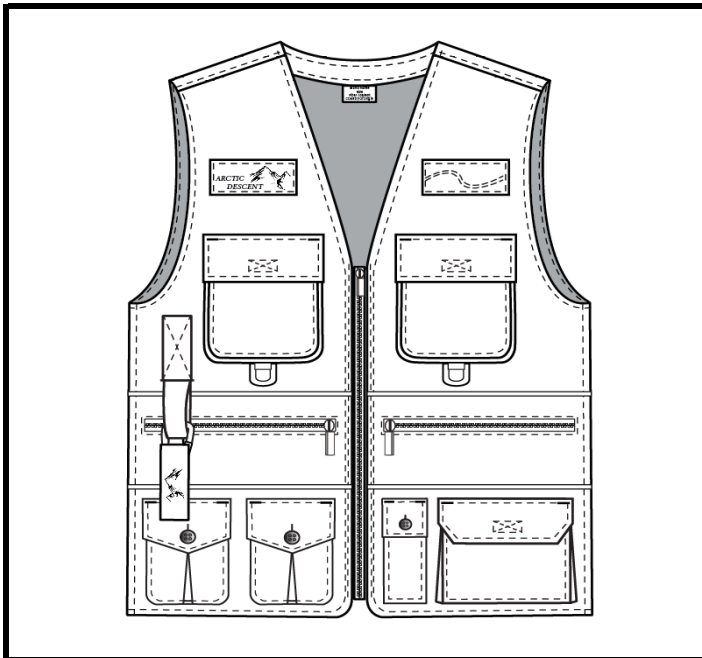

LABEL: Arctic Descent hangtag
Attached to loop that holds carabiner

LABEL:

POINTS OF MEASURE

STYLE #:	5106	FIT TYPE:	Classic		DESIGNER	Isaac Silva
FABRIC:	70% Cotton, 30% Nylon	SIZE RANGE:	S-XL		SEASON:	SS 2023
SAMPLE SIZE:	M	STATUS:	Prototype-1			
		TOL				
A. NECK DROP FRONT	3/8"	8"				
B. ARMHOLE HEIGHT	1/4"	9 1/2"				
C. SHOULDER LENGTH TO ARMHOLE	1/4"	6 3/4"				
D. COLLAR WIDTH	3/8"	1 3/4"				
E. DISTANCE FROM HPS TO FIRST PIPING PANEL	1/4"	12"				
F. WAIST 21" FROM HPS	1/8"	10 1/8"				
G. HPS TO SEW ON PATCH	1/4"	6"				
H. BOTTOM OF SEW ON PATCH TO TOP OF CARGO POCKET	3/8"	2 1/2"				
I. LENGTH OF SIDESEAM	3/8"	10 3/4"				
J. CHEST 1" BELOW ARMHOLE (FULL)	1/8"	10 1/8"				
K. DISTANCE BETWEEN PIPING TO ZIPPER POCKET	1/8"	2"				
L. DISTANCE BETWEEN CF ZIPPER TO CARGO POCKET	1/8"	2"				
M. DISTANCE BETWEEN CARABINER PATCH TO CARGO POCKET	1/8"	3/4"				
N. HEM	1/8"	1/4"				
O. DISTANCE BETWEEN CARABINER PATCH TO SIDESEAM	3/8"	3 1/4"				
P. DISTANCE BETWEEN BOTTOM OF CARGO POCKET TO PIPING	1/4"	1 3/4"				
Q. LENGTH OF MIDDLE PANEL BETWEEN PIPING	1/2"	5 3/4"				
R. BOTTOM	1/2"	16"				
S. LENGTH OF CF ZIPPER	1/4"	9 1/2"				
T. BACK OF NECKLINE	3/8"	6 1/2"				
U. HPS TO BACK YOKE WITH PIPING	1/4"	9 1/2"				
V. LENGTH OF BACK YOKE WITH PIPING	3/8"	20"				
W. LENGTH OF CB PIPING	1/4"	9"				
X. DISTANCE FROM SIDESEAM TO CB PIPING	3/8"	10"				

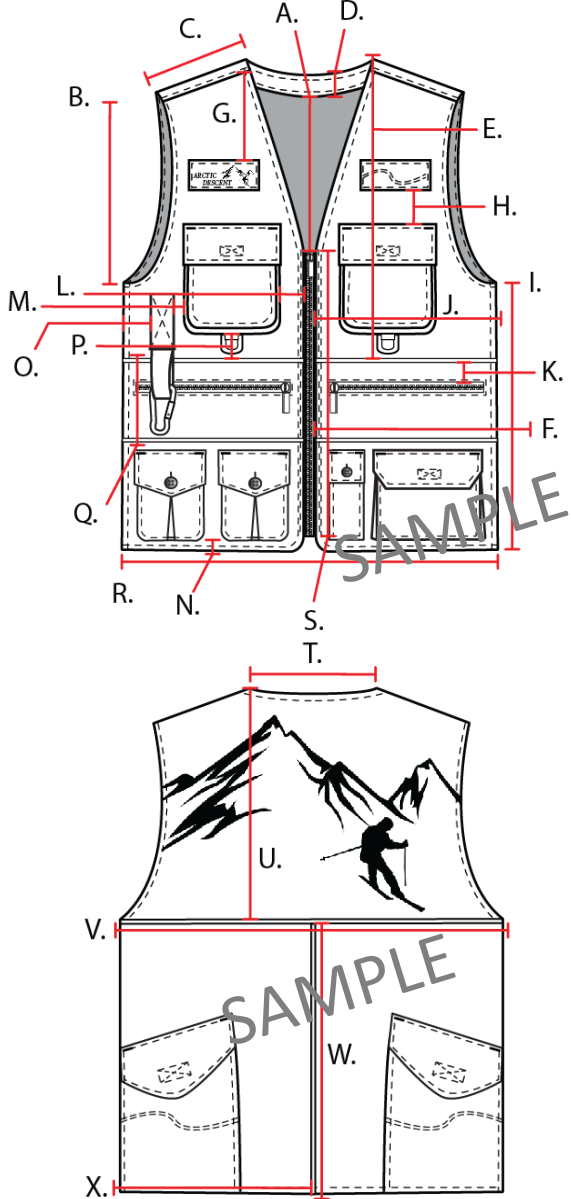

BILL OF MATERIALS

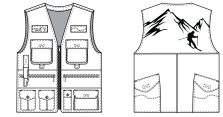

STYLE #:	5106	FIT TYPE:	Classic	DESIGNER	Isaac Silva
FABRIC:	70% Cotton, 30% Nylon	SIZE RANGE:	S-XL	SEASON:	SS 2023
SAMPLE SIZE:	M	STATUS:	Prototype-1		

FABRIC							
ITEM	PLACEMENT	SUPPLIER	CONTENT	WIDTH / WEIGHT / SIZE	FINISH	YIELD	COST
SELF FABRIC	Body	MOOD Fabrics	70% Cotton, 30% Nylon	57"	garment laundered, 60 min.	2 1/2 yds.	\$39.98
POCKETING	Cargo pockets	MOOD Fabrics	70% Cotton, 30% Nylon	57"	laundered, 60	1 yd.	\$7.99
THREAD-DTM BODY	Join & overlock	A & E	100% Spun polyester	tex 30	-	1 spool	\$0.99
THREAD-CONTRAST	Topstitch	A & E	100% Spun polyester	tex 90	-	1 spool	\$1.99

HARDWARE							
ITEM	PLACEMENT	SUPPLIER	DESCRIPTION	WIDTH	FINISH	YIELD	COST
CENTER FRONT ZIPPER:	CF	YKK Tokyo	10" Antique brass zipper	-	Antique brass	1	\$1.89
D-RING:	Bottom of top front cargo pockets	Wawak Sewing	Antique brass D-Ring	1/2"	Antique brass	2	\$0.98
BUTTON:	On patch pocket flaps	Wawak Sewing	4-Hole, Plastic button	22L	Matte	3	\$0.28
ARM SLEEVE PATCH:	CF left and right	Shopify	Sew on patch	5"	-	2	\$2.00
PIPING:	Right leg above and below knee zipper	Wawak Sewing	Reflective piping	1/8"	Reflective	1 yd.	\$2.45
CARABINER:	CF left	Wawak Sewing	Matte metal carabiner	-	Matte	1	\$1.75
VELCRO:	On cargo pocket flaps & back pockets	Wawak Sewing	Velcro	30"	-	1 yd.	\$0.75
ZIPPER:	Middle left and right panels above pockets	YKK Tokyo	6 1/2" Antique brass zipper	-	Antique brass	2	\$3.26

LABELING/ PACKAGING							
ITEM	PLACEMENT	SUPPLIER	DESCRIPTION	WIDTH	FINISH	YIELD	COST
HANGTAG	Attached to right pocket D-Ring	Shopify	Arctic Descent Hangtag	2" X 4"	matte	1	\$2
INTERIOR LABEL	Left side seam 4" above hem	Shopify	Wash and care label	1" X 3"	none	1	\$1
	Below collar on CB	Shopify	Brand, Size, Fiber content, Country of origin	1.5" X 1.5"	none	1	\$0.50

FABRIC SWATCHES:



CONSTRUCTION DETAILS SHEET

STYLE NUMBER: 5106

SIZE RANGE: S-XL

PROTO NUMBER: 1

SAMPLE SIZE: M

DESCRIPTION: Utility vest

SEASON: SS 2023

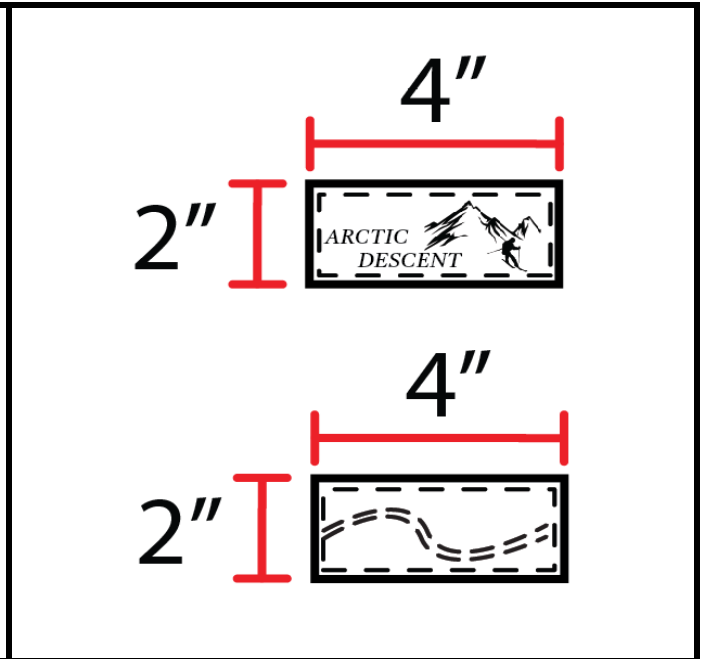
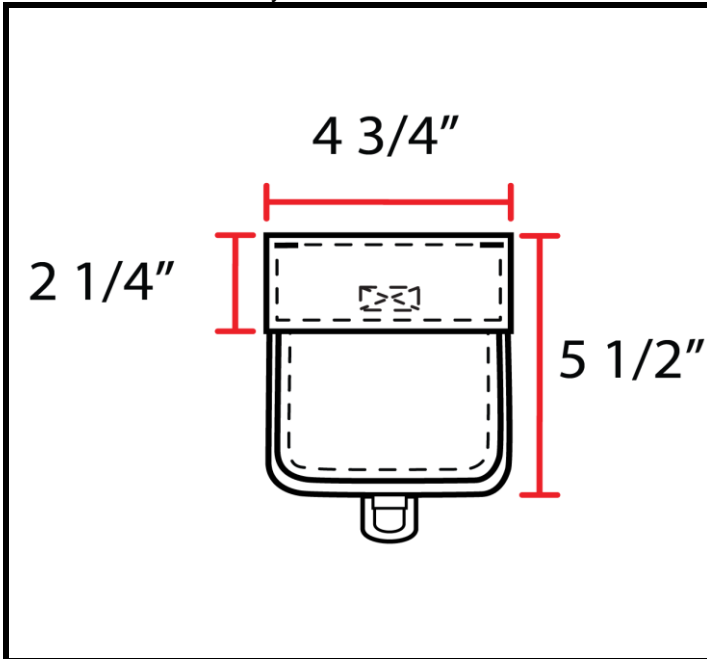

CONSTRUCTION DETAIL NUMBER & DESCRIPTION:
Front cargo pocket with D-Rings

CONSTRUCTION DETAIL NUMBER & DESCRIPTION:
Sew on patches

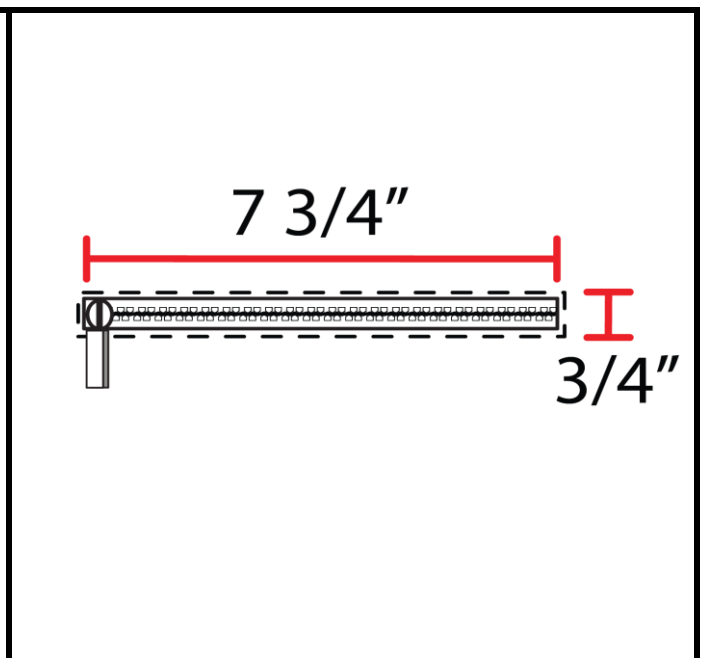
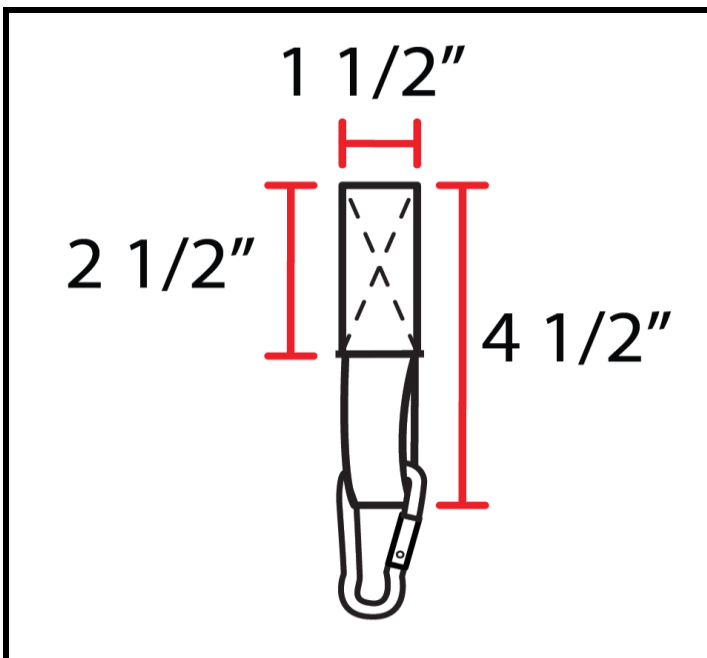

CONSTRUCTION DETAIL NUMBER & DESCRIPTION:
Carabiner loop

CONSTRUCTION DETAIL NUMBER & DESCRIPTION:
Front zipper pockets

CONSTRUCTION DETAILS SHEET

STYLE NUMBER: 5106

SIZE RANGE: S-XL

PROTO NUMBER: 1

SAMPLE SIZE: M

DESCRIPTION: Utility vest

SEASON: SS 2023

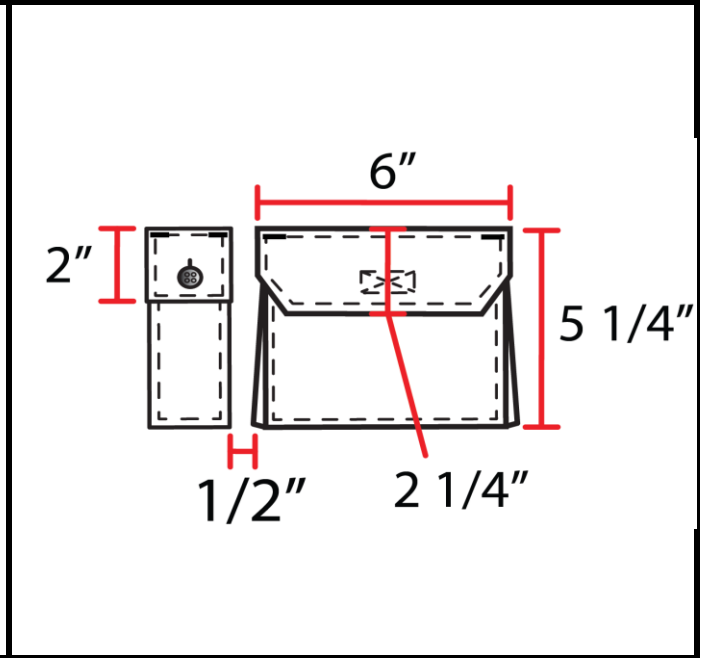
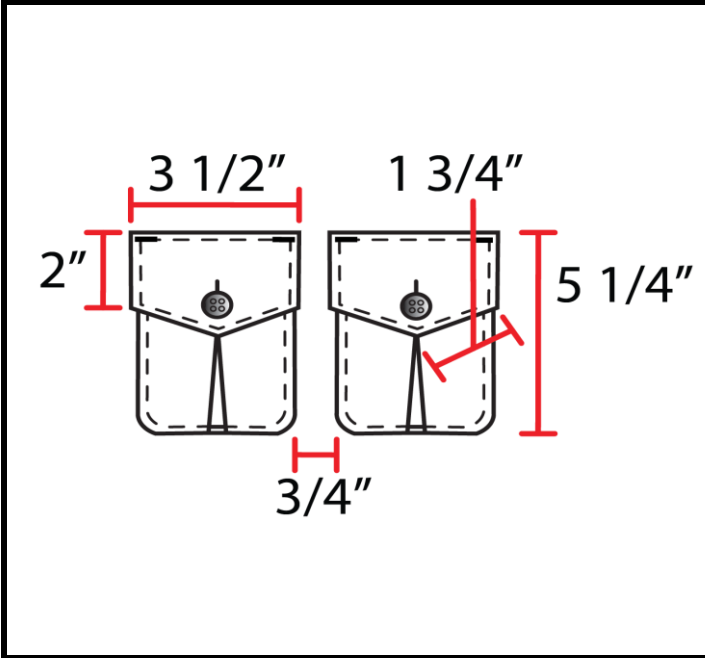

CONSTRUCTION DETAIL NUMBER & DESCRIPTION:
Front cargo pockets

CONSTRUCTION DETAIL NUMBER & DESCRIPTION:
Large and small front cargo pocket

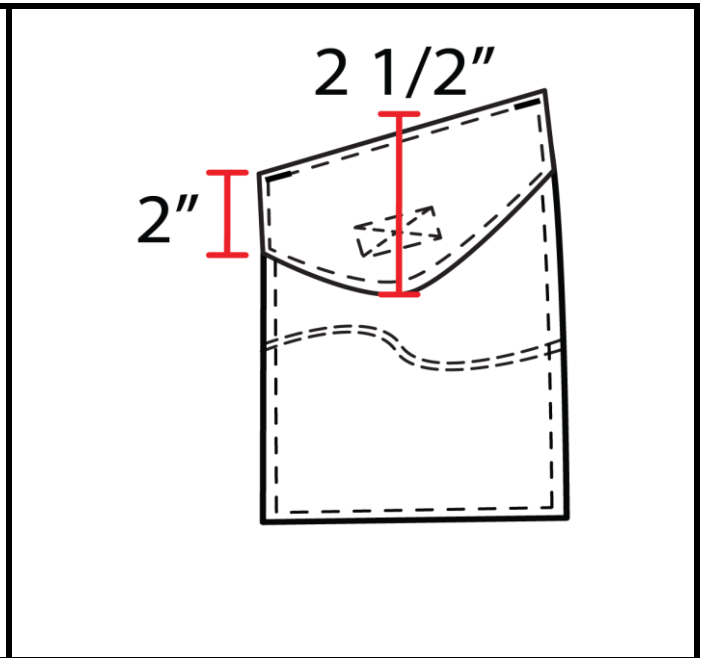
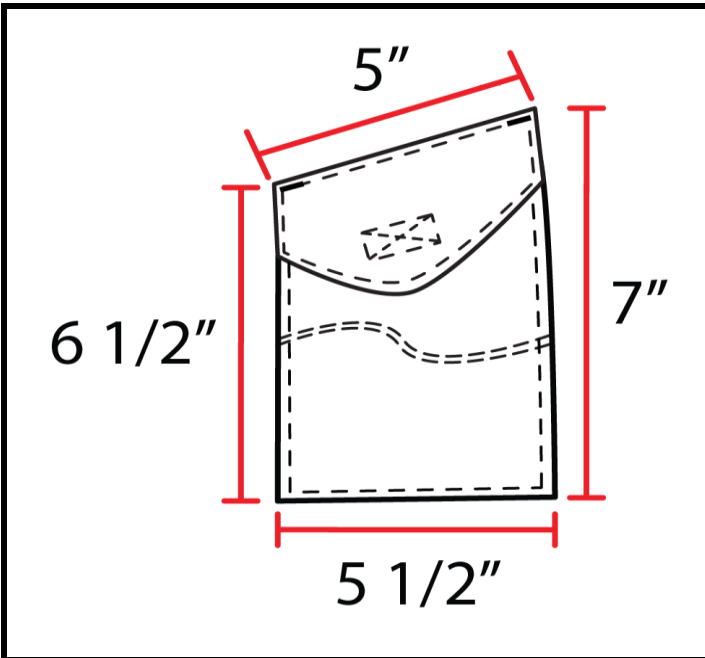

CONSTRUCTION DETAIL NUMBER & DESCRIPTION:
Back pockets

CONSTRUCTION DETAIL NUMBER & DESCRIPTION:
Back pocket flaps

Construction Page

STYLE #: 5106		FIT TYPE: Classic		DESIGNER: Isaac Silva	
FABRIC: 70% Cotton, 30% Nylon		SIZE RANGE: S-XL		SEASON: SS 2023	
Cutting Information: 1 way, lengthwise					
Stitches per Inch (SPI) 11 +/- 1 for joining, 8 +/- for topstitching					
AREA	DESCRIPTION	JOIN STITCH	SEAM FINISH	TOPSTITCH	INTER-LINING
FRNT & BCK	join & topstitch	single-needle lock	double-stitched	two needle lock (to match flatfell)	-
COLLAR	join & topstitch	single-needle lock	-	3/8"	-
YOKE	form & finish	1/4" two-needle bottom coverstitch			-
BARTACKS	see detail sketches	-	-	1/2"	-
FRONT POCKETS	see detail sketches	single-needle lock		1/4"	-
ARM HOLE	topstitch	single-needle lock	double-stitched	1/4"	-
BOTTOM OPENING	hem	single-needle lock	clean finish	1/2"	-
CLOSURES					
BUTTONHOLE	Buttonhole, keyhole	-	-	-	-
ZIPPER POCKETS	-	single-needle lock	-	2 rows, 1/4"	-
FRNT POCKETS	join & topstitch	single-needle lock	double-stitched	2 rows, 1/4"	-

COLORWAYS SHEET

STYLE NUMBER: 5106
 PROTO NUMBER: 1
 DESCRIPTION: Utility vest

SIZE RANGE: S-XL
 SAMPLE SIZE: M
 SEASON: SS 2023

MATERIAL	DESCRIPTION	COLORWAY #1	COLORWAY #2	COLORWAY #3	COLORWAY #4
SELF FABRIC:	70% Cotton, 30% Nylon	Olive 18-0328 TCX	Black 419	Soft Chambray 16-4016 TCX	
THREAD 1:	100% Spun polyester	Olive	Black	Light blue gray	
THREAD 2:	100% Spun polyester	Dark Olive	Black	White	
THREAD 3:					
CONTRAST 1:					
CONTRAST 2:					
CONTRAST 3:					
CONTRAST 4:					
LINING 1:					
LINING 2:					
POCKETING:	70% Cotton, 30% Nylon	Olive 18-0328 TCX	Black 419	Soft Chambray 16-4016 TCX	
INTERFACING 1:					
INTERFACING 2:					
INTERFACING 3:					
TRIM 1:	4-Hole, Plastic button	Black	Black	Black	
TRIM 2:	Antique brass D-Ring	Antique brass	Antique brass	Antique brass	
TRIM 3:	Matte metal carabiner	Matte black	Matte black	Matte gray	
TRIM 4:	Antique brass zipper	Antique brass	Antique brass	Antique brass	
TRIM 5:	Reflective piping	White	White	White	
TRIM 6:					
EMBROIDERY:					
BEADING:					
APPLIQUE:					
STITCHING:					

SAMPLE TRACKING SHEET

STYLE NUMBER:	5106	SAMPLE SIZE	M
DESCRIPTION:	Utility vest	SEASON:	SS 2023

TYPE OF SAMPLE:	First prototype	DATE SAMPLE RECEIVED:	6/28/2022
FIT NOTES:	_____	APPROVED?	YES NO
CONSTRUCTION NOTES:	Increase distance from HPS to first piping panel to 12"	APPROVED?	YES NO
	Increase length of CF zipper by 1/2"		
	Decrease length of CB piping by 1/2"		
MATERIALS NOTES:	_____	APPROVED?	YES NO
OTHER NOTES:	_____	APPROVED?	YES NO
ACTION:	SAMPLE APPROVED AS IS	REQUEST NEW SAMPLE WITH ABOVE CHANGES	
DATE APPROVAL OR REQUEST COMMUNICATED:	6/29/2022		

TYPE OF SAMPLE:	Second prototype	DATE SAMPLE RECEIVED:	7/7/2022
FIT NOTES:	_____	APPROVED?	YES NO
CONSTRUCTION NOTES:	Increase neck drop front by 1"	APPROVED?	YES NO
	Increase distance from HPS to first piping panel to 12"		
	Reduce length of middle panel between piping by 1"		
MATERIALS NOTES:	_____	APPROVED?	YES NO
OTHER NOTES:	_____	APPROVED?	YES NO
ACTION:	SAMPLE APPROVED AS IS	REQUEST NEW SAMPLE WITH ABOVE CHANGES	
DATE APPROVAL OR REQUEST COMMUNICATED:	7/7/2022		

TYPE OF SAMPLE:	Third prototype	DATE SAMPLE RECEIVED:	7/14/2022
FIT NOTES:	_____	APPROVED?	YES NO
CONSTRUCTION NOTES:	_____	APPROVED?	YES NO
MATERIALS NOTES:	_____	APPROVED?	YES NO
OTHER NOTES:	_____	APPROVED?	YES NO
ACTION:	SAMPLE APPROVED AS IS	REQUEST NEW SAMPLE WITH ABOVE CHANGES	
DATE APPROVAL OR REQUEST COMMUNICATED:	7/14/2022		